

DATA SHEET

TDA1574T Integrated FM tuner for radio receivers

Product specification
File under Integrated Circuits, IC01

August 1990

Integrated FM tuner for radio receivers

TDA1574T

GENERAL DESCRIPTION

The TDA1574T is an integrated FM tuner circuit designed for use in the RF/IF section of car radios and home receivers. The circuit contains a mixer and an oscillator and a linear IF amplifier for signal processing. The circuit also incorporates the following features.

Features

- Keyed Automatic Gain Control (AGC)
- Regulated reference voltage
- Buffered oscillator output
- Electronic standby switch
- Internal buffered mixer driving.

QUICK REFERENCE DATA

PARAMETER	CONDITIONS	SYMBOL	MIN.	TYP.	MAX.	UNIT
Supply voltage range (pin 17)		V_P	7	–	14	V
Mixer input bias voltage (pins 1 and 2)		$V_{1,2-4}$	–	1	–	V
Noise factor		NF	–	9	–	dB
Oscillator output voltage (pin 6)		V_{6-4}	–	2	–	V
Output admittance at pin 6	$f = 108.7 \text{ MHz}$	Y_{22}	–	$1.5 + j2$		ms
Oscillator output buffer DC output voltage (pin 9)		V_{9-4}	–	6	–	V
Total harmonic distortion		THD	–	–15	–	dB
Linear IF amplifier output voltage (pin 12)		V_{12-4}	–	4.5	–	V
Noise factor	$R_S = 300 \Omega$	NF	–	6.5	–	dB
Keyed AGC output voltage range (pin 20)		V_{20-4}	0.5	–	$V_P - 0.3$	V

PACKAGE OUTLINE

20-lead mini-pack; plastic (SO20; SOT163A); SOT163-1; 1996 September 9.

Integrated FM tuner for radio receivers

TDA1574T

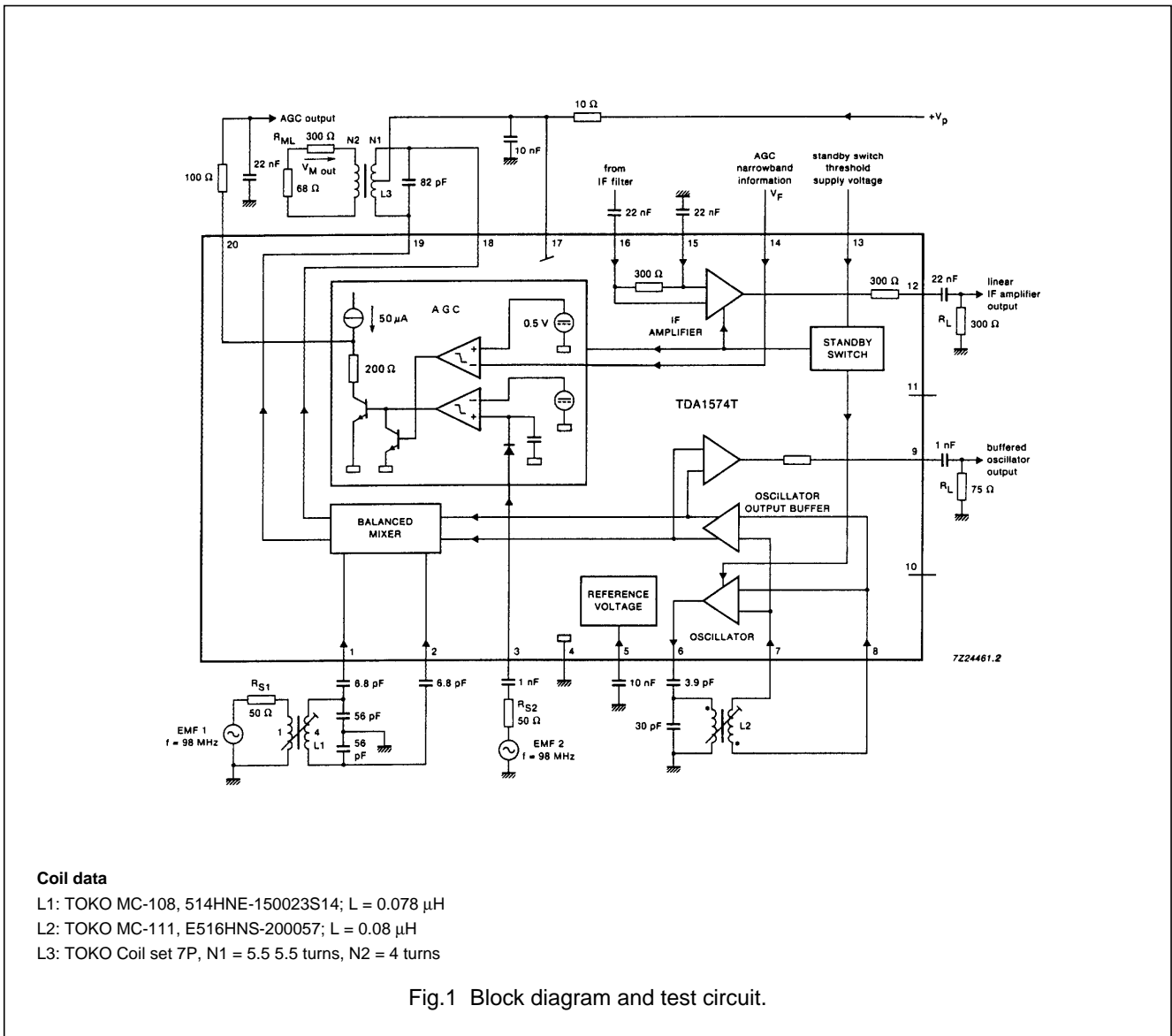

Coil data

- L1: TOKO MC-108, 514HNE-150023S14; L = 0.078 μ H
- L2: TOKO MC-111, E516HNS-200057; L = 0.08 μ H
- L3: TOKO Coil set 7P, N1 = 5.5.5.5 turns, N2 = 4 turns

Fig.1 Block diagram and test circuit.

Integrated FM tuner for radio receivers

TDA1574T

PINNING

1.	Mixer input 1
2.	Mixer input 2
3.	Wideband information input
4.	Ground
5.	Voltage reference
6.	Oscillator output
7.	Oscillator input 1
8.	Oscillator input 2
9.	Buffered oscillator output
10.	Not connected
11.	Not connected
12.	IF output
13.	Standby switch
14.	Narrowband information input
15.	IF input 1
16.	IF input 2
17.	Supply voltage
18.	Mixer output 1
19.	Mixer output 2
20.	AGC output

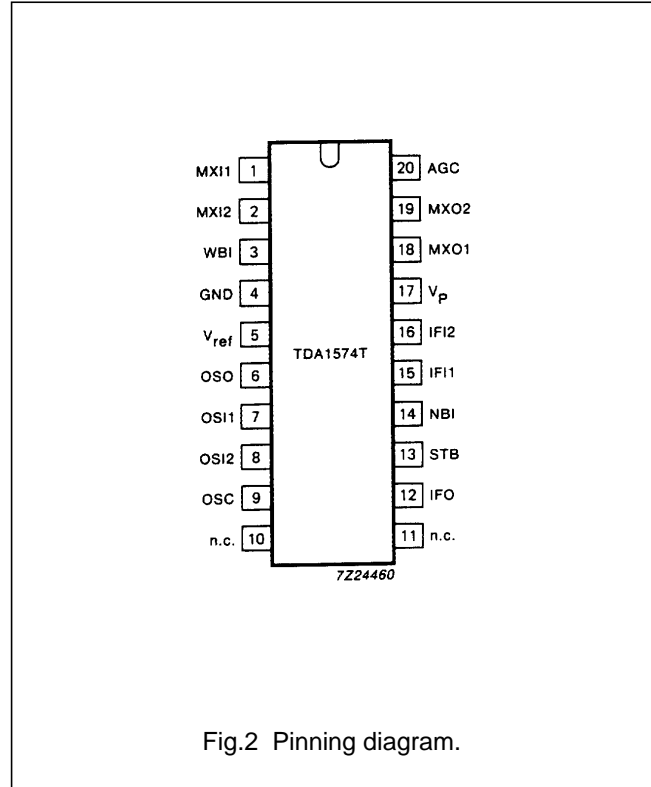

Fig.2 Pinning diagram.

FUNCTIONAL DESCRIPTION

Mixer

The mixer circuit uses a double balanced multiplier with a preamplifier (common base input) in order to obtain a large signal handling range and low oscillator radiation.

Oscillator

The oscillator circuit uses an amplifier with a differential input. Voltage regulation is achieved by utilizing the symmetrical tan h-transfer-function to obtain low order 2nd harmonics.

Linear IF amplifier

The IF amplifier is a one stage, differential input, wideband amplifier with an output buffer.

Keyed AGC

The AGC processor combines narrow and wideband information via an RF level detector, a comparator and an ANDing stage. The level dependent current sinking output has an active load which sets the AGC threshold.

The AGC function can either be controlled by a combination of wideband narrowband information (keyed AGC) or by a wideband/narrowband information only. If narrowband AGC is required pin 3 should be connected to pin 5. If wideband AGC is required pin 14 should be connected to pin 15.

Integrated FM tuner for radio receivers

TDA1574T

RATINGS

Limiting values in accordance with the Absolute Maximum System (IEC 134); note 1.

PARAMETER	CONDITIONS	SYMBOL	MIN.	MAX.	UNIT
Supply voltage (pin 17)		V_{17-4}	–	14	V
Mixer output voltage (pins 18 and 19)		$V_{18,19-4}$	–	35	V
Standby switch input voltage (pin 13)		V_{13-4}	–	23	V
Reference voltage (pin 5)		V_{5-4}	–	7	V
Total power dissipation		P_{tot}	–	500	mW
Storage temperature range		T_{stg}	–55	+ 150	°C
Operating ambient temperature range		T_{amb}	–40	+ 85	°C

Notes to the ratings

1. All pins are short-circuit protected to ground.

THERMAL RESISTANCE

From junction to ambient (in free air)

$$R_{th\ j-a} = 95\ K/W$$

Integrated FM tuner for radio receivers

TDA1574T

CHARACTERISTICS $V_P = V_{17-4} = 8.5 \text{ V}$; $T_{\text{amb}} = 25 \text{ }^\circ\text{C}$; measured in test circuit Fig.1;

All measurements are with respect to ground (pin 4); unless otherwise specified

PARAMETER	CONDITIONS	SYMBOL	MIN.	TYP.	MAX.	UNIT
Supply (pin 17)						
Supply voltage	$V_P = V_{17}$	V_{17}	7	–	14	V
Supply current (except mixer)	$I_P = I_{17}$	I_{17}	16	23	30	mA
Reference voltage (pin 5)		V_5	4.0	4.2	4.4	V
Mixer						
DC characteristics						
Input bias voltage (pins 1 and 2)		$V_{1,2}$	–	1	–	V
Output voltage (pins 18 and 19)		$V_{18,19}$	4	–	35	V
Other current (pins 18 and 19)		I_{18+19}	–	4.5	–	mA
AC characteristics						
Noise figure	$f_i = 98 \text{ MHz}$	NF	–	9	–	dB
Noise figure including transforming network		NF	–	11	–	dB
3rd order intercept point		$EMF1_{IP3}$	–	115	–	dB/ μV
Conversion power gain	note 1	G_{CP}	–	14	–	dB
Input resistance (pins 1 and 2)		$R_{1,2}$	–	14	–	Ω
Output capacitance (pins 18 and 19)		$C_{18,19}$	–	13	–	pF
Oscillator						
DC characteristics						
Input voltage (pins 7 and 8)		$V_{7,8}$	–	1.3	–	V
Output voltage (pin 6)		V_6	–	2	–	V
AC characteristics						
Residual FM (bandwidth = 300 Hz to 15 kHz)	de-emphasis = 50 μs	Δf	–	2.2	–	Hz
Linear IF amplifier						
DC characteristics						
Input bias voltage (pin 15)		V_{15}	–	1.2	–	V

Integrated FM tuner for radio receivers

TDA1574T

PARAMETER	CONDITIONS	SYMBOL	MIN.	TYP.	MAX.	UNIT
Output voltage (pin 12)		V_{12}	–	4.5	–	V
AC characteristics	$f_i = 10.7$ MHz					
Input impedance		R_{16-15}	240	300	360	Ω
		C_{16-15}	–	13	–	pF
Output impedance		R_{12}	240	300	360	Ω
		C_{12}	–	3	–	pF
Voltage gain	note 2	G_v	27	30	–	dB
Voltage gain with variation of temperature	$T_{amb} = -40$ to $+85$ °C	ΔG_T	–	0	–	dB
1 dB compression point (RMS value)						
at $V_P = 8.5$ V		$V_{12(rms)}$	–	750	–	mV
at $V_P = 7.5$ V		$V_{12(rms)}$	–	550	–	mV
Signal-to-noise ratio	$R_S = 300$ Ω	S/N	–	6.5	–	dB
Keyed AGC						
DC characteristics						
Output voltage range (pin 20)		ΔV_{20}	0.5	–	$V_P - 0.3$	V
AGC output current						
at $I_3 = 0$ or $V_{14} = 450$ mV; $V_{20} = V_P/2$		$-I_{20}$	25	50	100	μ A
at $V_3 = 2$ V and $V_{14} = 1$ V; $V_{20} = V_{15}$		I_{20}	2	–	5	mA
Narrowband threshold						
at $V_3 = 2$ V; $V_{14} = 550$ mV		V_{20}	–	–	1	V
at $V_3 = 2$ V; $V_{14} = 450$ mV		V_{20}	$V_P - 0.3$	–	–	V
AC characteristics	$f_i = 98$ MHz					
Input impedance		R_3	–	4	–	k Ω
		C_3	–	3	–	pF

Integrated FM tuner for radio receivers

TDA1574T

PARAMETER	CONDITIONS	SYMBOL	MIN.	TYP.	MAX.	UNIT
Wideband threshold (RMS value) (see Figs 3, 4, 5 and 6) at $V_{14} = 0.7$ V; $V_{20} = V_P/2$; $I_{20} = 0$		$EMF_{2(rms)}$	–	17	–	mV
Oscillator output buffer (pin 9)						
DC output voltage		V_9	–	6	–	V
Oscillator output voltage (RMS value) at $R_L = \infty$; $C_L = 2$ pF at $R_L = 75$ Ω		$V_{9(rms)}$	–	110	–	mV
		$V_{9(rms)}$	30	50	–	mV
DC output resistance		R_{9-17}	–	2.5	–	k Ω
Signal purity						
Total harmonic distortion		THD	–	–15	–	dB
Spurious frequencies at $EMF_1 = 1$ V; $R_{S1} = 50$ Ω		f_s	–	–35	–	dB
Electronic standby switch (pin 11)						
Oscillator; linear IF amplifier; AGC	$T_{amb} = -40$ to $+85$ $^{\circ}\text{C}$					
Input switching voltage for threshold ON	$V_{20} = > V_P - 3$ V	V_{13}	0	–	2.3	V
for threshold OFF	$V_{20} = < 0.5$ V	V_{13}	3.3	–	23	V
Input current at ON condition	$V_{13} = 0$ V	$-I_{13}$	–	–	150	μA
at OFF condition	$V_{13} = 23$ V	$-I_{13}$	–	–	10	μA
Input voltage	$I_{13} = 0$	V_{13}	–	–	4.4	V

Notes to the characteristics

- Power gain conversion is equated by the following equation:

$$10 \log \frac{4 (V_{M(out)} 10.7 \text{ MHz})^2}{(EMF_1 98 \text{ MHz})^2} \times \frac{R_{S1}}{R_{ML}}$$

- Voltage gain is equated by the following equation:

$$20 \log \frac{V_{12}}{V_{16-15}}$$

Integrated FM tuner for radio receivers

TDA1574T

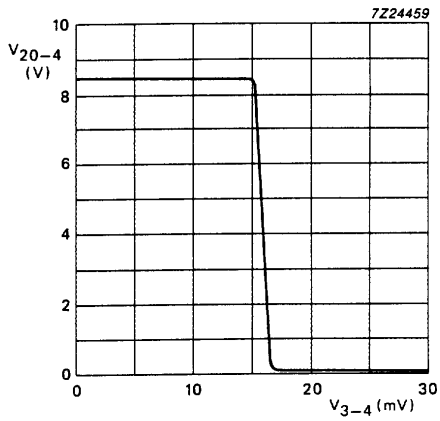

Fig.3 Keyed AGC output voltage V_{20} as a function of RMS input voltage V_3 . Measured in test circuit Fig.1 at $V_{14} = 0.7$ V; $I_{20} = 0$.

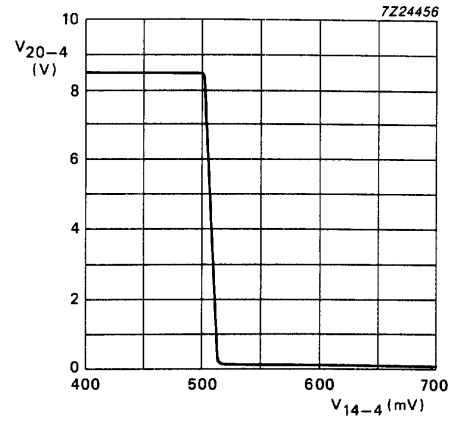

Fig.4 Keyed AGC output voltage V_{20} as a function of input voltage V_{14} . Measured in test circuit Fig.1 at $V_3 = 2$ V; $I_{20} = 0$.

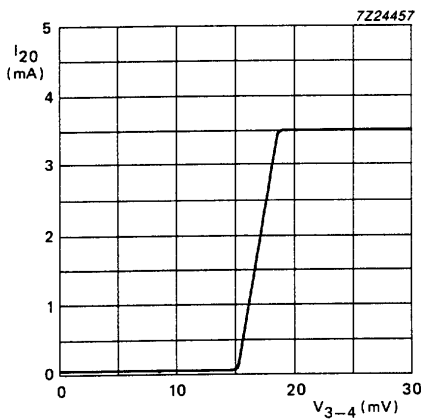

Fig.5 Keyed AGC output current I_{20} as a function of RMS input voltage V_3 . Measured in test circuit Fig.1 at $V_{14} = 0.7$ V; $V_{20} = 8.5$ V.

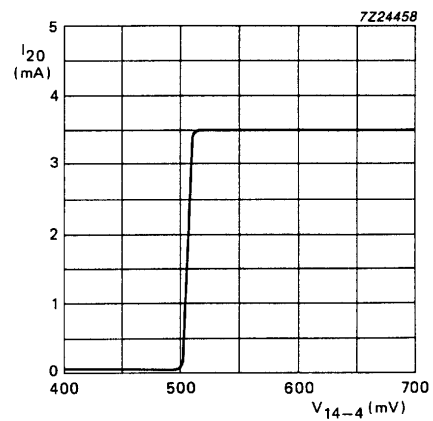
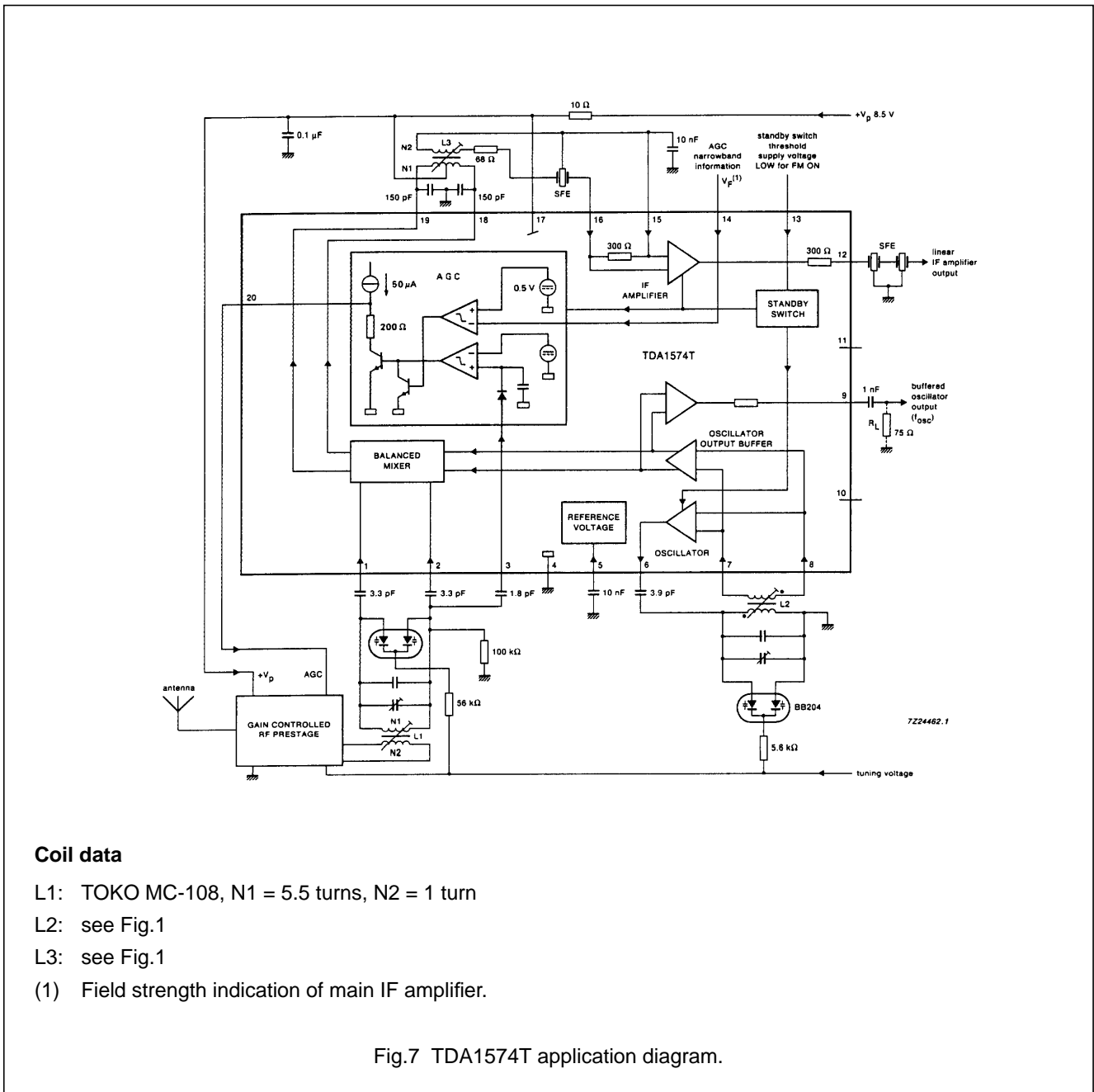

Fig.6 Keyed AGC output current I_{20} as a function of input voltage V_{14} . Measured in test circuit Fig.1 at $V_3 = 2$ V; $V_{20} = 8.5$ V.

Integrated FM tuner for radio receivers

TDA1574T



Integrated FM tuner for radio receivers

TDA1574T

PACKAGE OUTLINE

SO20: plastic small outline package; 20 leads; body width 7.5 mm

SOT163-1

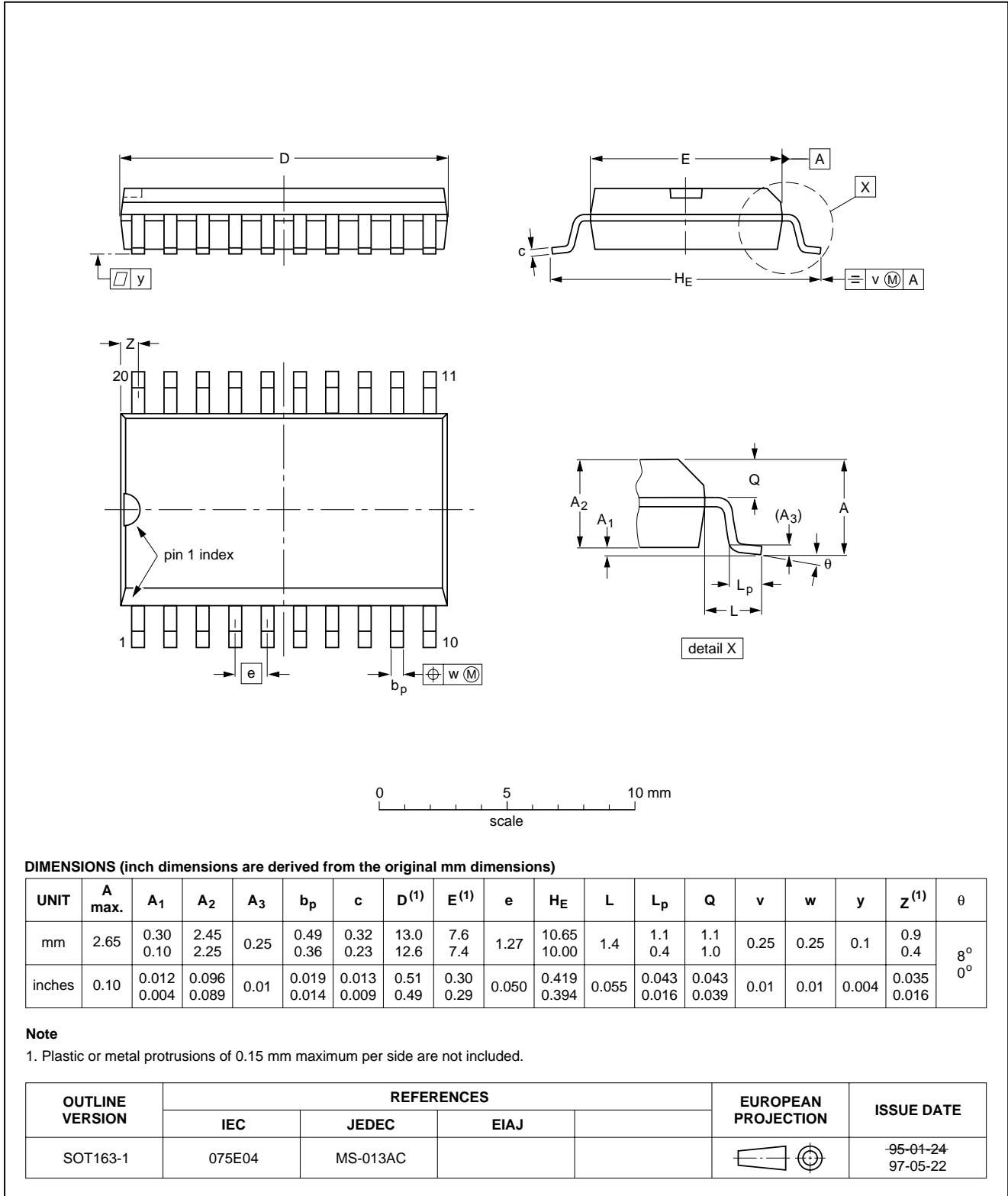

Integrated FM tuner for radio receivers

TDA1574T

SOLDERING

Introduction

There is no soldering method that is ideal for all IC packages. Wave soldering is often preferred when through-hole and surface mounted components are mixed on one printed-circuit board. However, wave soldering is not always suitable for surface mounted ICs, or for printed-circuits with high population densities. In these situations reflow soldering is often used.

This text gives a very brief insight to a complex technology. A more in-depth account of soldering ICs can be found in our *"IC Package Databook"* (order code 9398 652 90011).

Reflow soldering

Reflow soldering techniques are suitable for all SO packages.

Reflow soldering requires solder paste (a suspension of fine solder particles, flux and binding agent) to be applied to the printed-circuit board by screen printing, stencilling or pressure-syringe dispensing before package placement.

Several techniques exist for reflowing; for example, thermal conduction by heated belt. Dwell times vary between 50 and 300 seconds depending on heating method. Typical reflow temperatures range from 215 to 250 °C.

Preheating is necessary to dry the paste and evaporate the binding agent. Preheating duration: 45 minutes at 45 °C.

Wave soldering

Wave soldering techniques can be used for all SO packages if the following conditions are observed:

- A double-wave (a turbulent wave with high upward pressure followed by a smooth laminar wave) soldering technique should be used.
- The longitudinal axis of the package footprint must be parallel to the solder flow.
- The package footprint must incorporate solder thieves at the downstream end.

During placement and before soldering, the package must be fixed with a droplet of adhesive. The adhesive can be applied by screen printing, pin transfer or syringe dispensing. The package can be soldered after the adhesive is cured.

Maximum permissible solder temperature is 260 °C, and maximum duration of package immersion in solder is 10 seconds, if cooled to less than 150 °C within 6 seconds. Typical dwell time is 4 seconds at 250 °C.

A mildly-activated flux will eliminate the need for removal of corrosive residues in most applications.

Repairing soldered joints

Fix the component by first soldering two diagonally-opposite end leads. Use only a low voltage soldering iron (less than 24 V) applied to the flat part of the lead. Contact time must be limited to 10 seconds at up to 300 °C. When using a dedicated tool, all other leads can be soldered in one operation within 2 to 5 seconds between 270 and 320 °C.

Integrated FM tuner for radio receivers

TDA1574T

DEFINITIONS

Data sheet status	
Objective specification	This data sheet contains target or goal specifications for product development.
Preliminary specification	This data sheet contains preliminary data; supplementary data may be published later.
Product specification	This data sheet contains final product specifications.
Limiting values	
Limiting values given are in accordance with the Absolute Maximum Rating System (IEC 134). Stress above one or more of the limiting values may cause permanent damage to the device. These are stress ratings only and operation of the device at these or at any other conditions above those given in the Characteristics sections of the specification is not implied. Exposure to limiting values for extended periods may affect device reliability.	
Application information	
Where application information is given, it is advisory and does not form part of the specification.	

LIFE SUPPORT APPLICATIONS

These products are not designed for use in life support appliances, devices, or systems where malfunction of these products can reasonably be expected to result in personal injury. Philips customers using or selling these products for use in such applications do so at their own risk and agree to fully indemnify Philips for any damages resulting from such improper use or sale.